

# Pebble Lane

## LIVING

### ASSEMBLY INSTRUCTIONS

## ACACIA WHITE WASHED DINING CHAIR WITH ARMS PS19C-80B-AWW

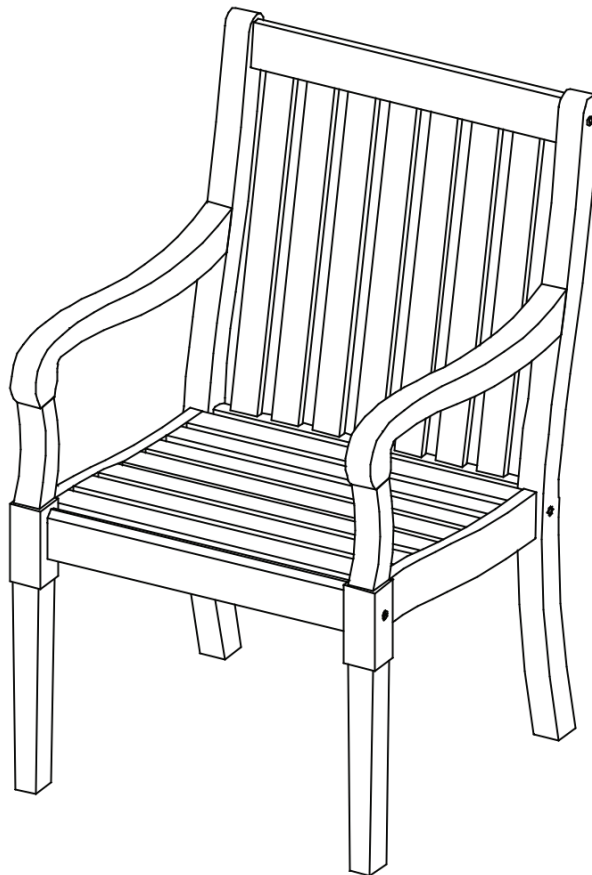

### CUSTOMER SERVICE INFORMATION



Please do not return to the store. If any pieces are missing call (402) 953-1048 from 10:00 am to 3.00 pm CST (Monday to Friday) for replacement parts. For faster service, have the style number handy when calling.

## GENERAL INFORMATION & TIPS

1. Please read the assembly instructions prior to assembling the chair.
2. To avoid damage, assemble the chair on a non-abrasive surface such as carpet.
3. Make sure all bolts tightly fastened before the chair is used.
4. This chair is not for commercial use.

Please make sure you have all parts before beginning assembly. Please wait until all steps are completed before tightening bolts.

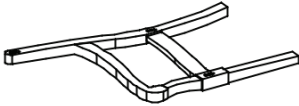
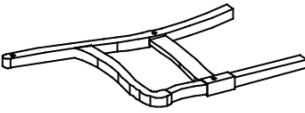
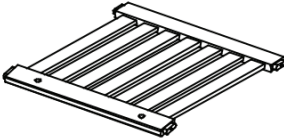
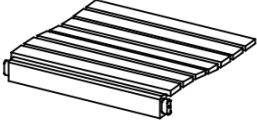
## PARTS AND HARDWARE LIST

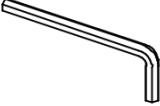
A1. Right side frame	A2. Left side frame	B. Back support	C. Seat
			
QTY: 1pc	QTY: 1pc	QTY: 1pc	QTY: 1pc
D. Screw	E. Screw	F. Allen key	
			
QTY: 2pcs + 1	QTY: 4pcs + 1	QTY: 1pc	

## STEP 1

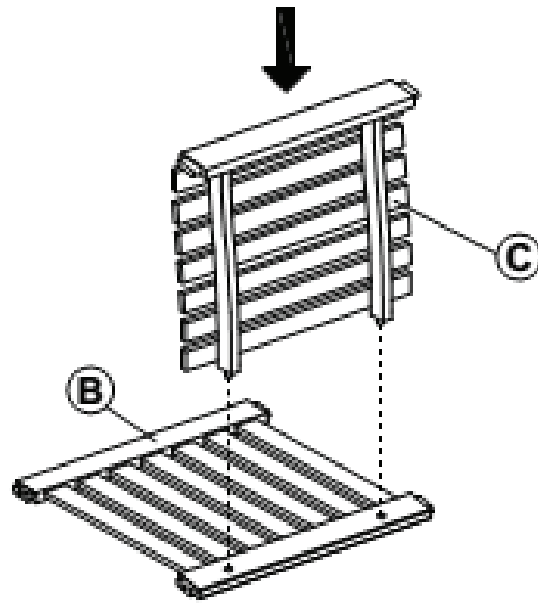

## STEP 2

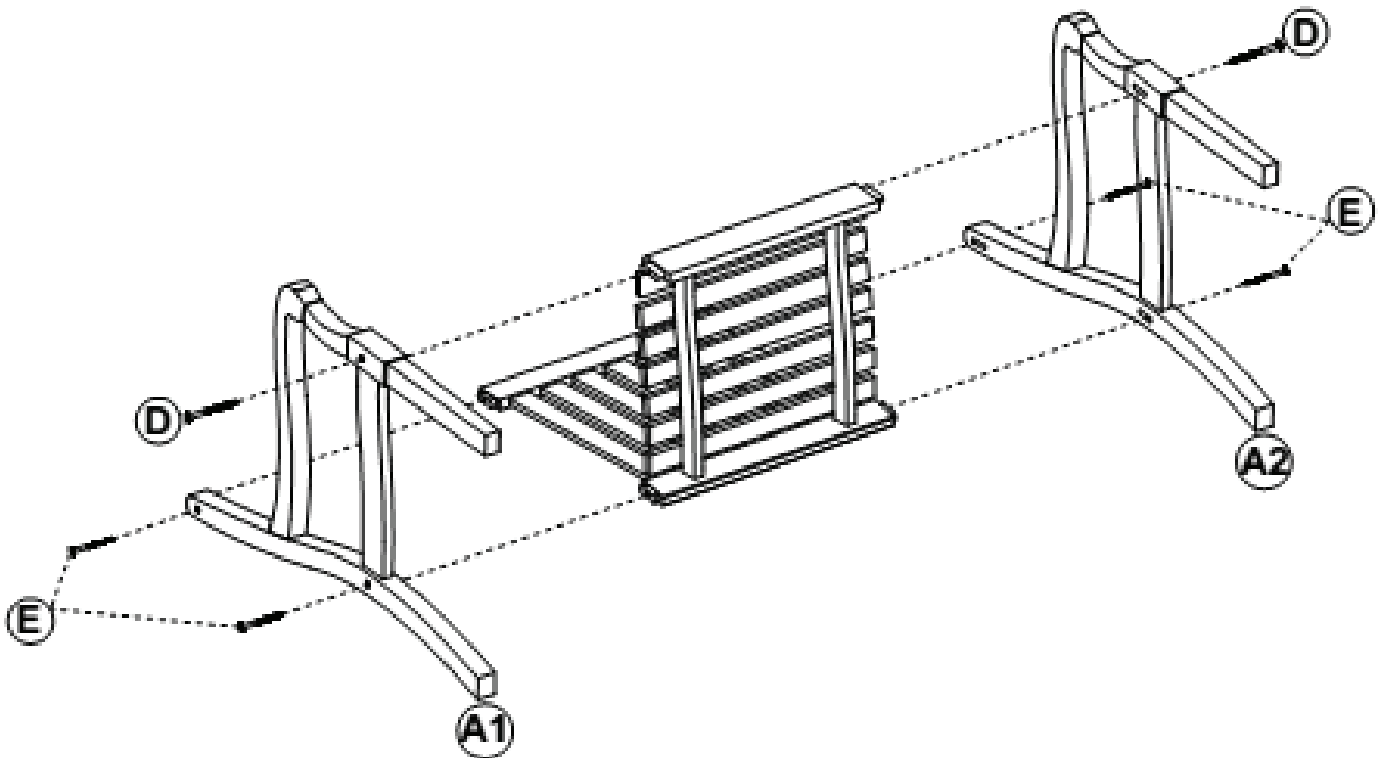

Pebble Lane  
LIVING

## **MAINTENANCE**

Wood is a living material that continues to respond to climate condition even after being made into a piece of furniture.

Left untreated, it will weather to a silvery grey outdoors. During normal weathering, wood may crack slightly due to changes in the moisture. This does not affect the structural integrity of your furniture. We recommend periodically applying oak/teak oil to maintain its natural finish.

In order to maintain the product's durability, please read carefully.

To reinforce its weatherproof ability, this product has been treated with oil on its surface during production. Before using, wipe with clean, dry cloth. If possible, apply the oil and rub the finish lightly with a soft cloth to obtain a shinier look.

Periodic applying oil (commonly known as oak/teak oil; Easy to purchase from the stores/supermarket) will ensure the timber is protected and its appearance maintained.

After season, apply oil and keep the furniture shaded or disassembled and repack the furniture for storage.

**Do not leave your furniture in puddles of water or on wet ground.**

**Cover your furniture during winter months or move covered storage, if in wet climates.**

**The manufacturer supports protection of the world's forest resources and is diligent in sourcing legally harvested wood.**

Thank you

The manufacturer

## 1 year Limited Warranty

The furniture is warranted to be free from defects in material and workmanship of the original product when purchased from one of our authorized dealers. If a product fails and is under the terms of our limited warranty, the item will be replaced, usually for a small fee. In the case of discontinued models, an item of similar quality and style will be offered to the customer.

- 1 year limited frame warranty

Frames are warranted to be free from defects in material and workmanship.

Fading or discoloring caused by putting the product under sunlight or rain is not covered by this limited warranty. Damage to the frame due to improper assembly or exposure to water and sub-freezing temperatures is not covered.

(Do NOT allow water to accumulate inside frame)

- Finish

The finish is warranted against peeling, cracking, or blistering for a period of 1 year, provided the unit has not been scratched or abraded.

Scratches and chips resulting from normal wear and use are not covered.

Peeling resulting from exposure to elements is not covered.

Warranty Exclusions: Furniture used for commercial, contractor or any non-residential purpose, clearance items, display models or item purchased “as is”, freight damage, furniture damaged by acts of nature, vandalism, fire, abuse, lack of proper care and maintenance, or improper assembly, straps and fabric against fading or discoloration from exposure to elements, oil spills, fluids or chemicals; glass against breakage; hardware against corrosion or rusting; buckling or splitting of tubing resulting from exposure to water and freezing temperatures. Also excluded: loss of use or time, inconvenience, money, travel, packaging or any other consequential or incidental damages. In no event shall the manufacturer’s responsibility exceed the value of the replacement product.

Warranty is to the original purchaser when items are purchased from one of our authorized retailers and is not transferable. All warranty claims must be submitted with a dated receipt within the warranty period. Should replacement of the warranty item be unavailable, the manufacturer reserves the right to substitute items of our choice that are of similar style and quality. For quality control purposes and verification, we reserve the right to request photography of the damage item(s). The terms of this warranty are subject to change without notice.

**Pebble Lane**  
LIVING